

How to use Document Camera in ASTF 500

TURN ON PROJECTOR

1. On the Screen Control, press the Down switch.
2. On the Projector Control, press the On/Off button. It may take up to one minute for the lamp to light up.
3. On the Projector Control, press the Doc Camera button.

TURN ON DOC CAMERA

Unfold the lighting unit arms fully until they come to the deadend. Unfold arm 1 and then arm 2 as illustrated.

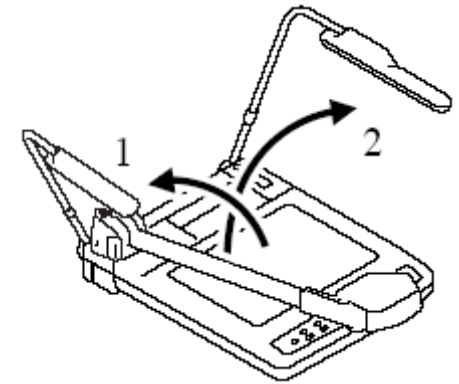

Press the column lock release button, and raise the column until the column lock release returns to its original location. Make sure that the column is locked properly.

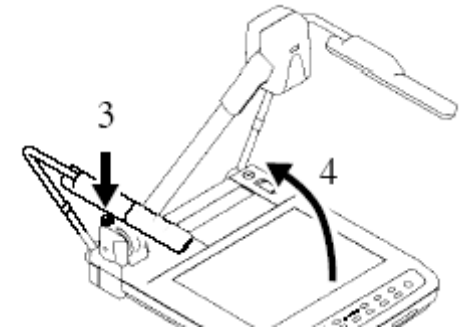

Turn ON the power switch.

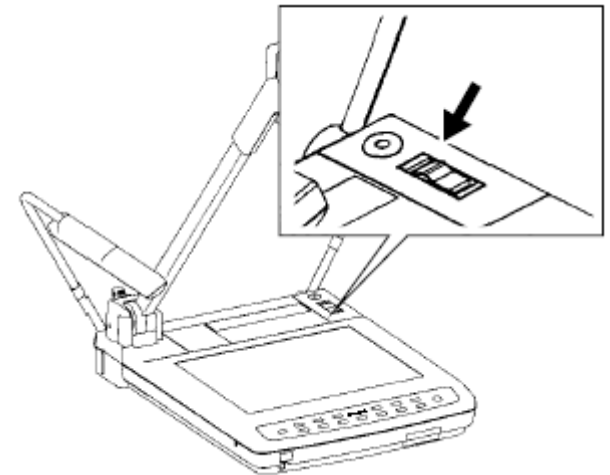

LAMP

For regular papers, press the [UPPER] button.
For transparencies press the [BASE] button:

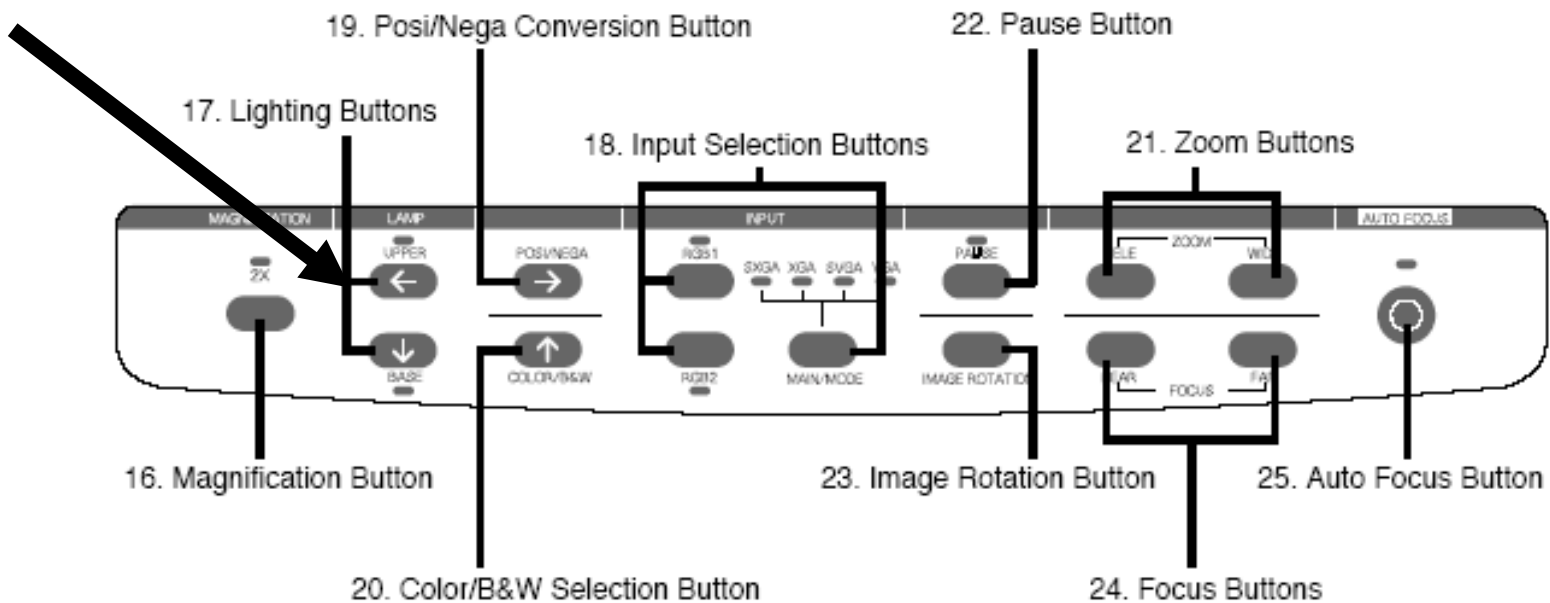

INPUT

Press the [MAIN MODE] button.
Never press the [RGB1] or [RGB2] buttons.

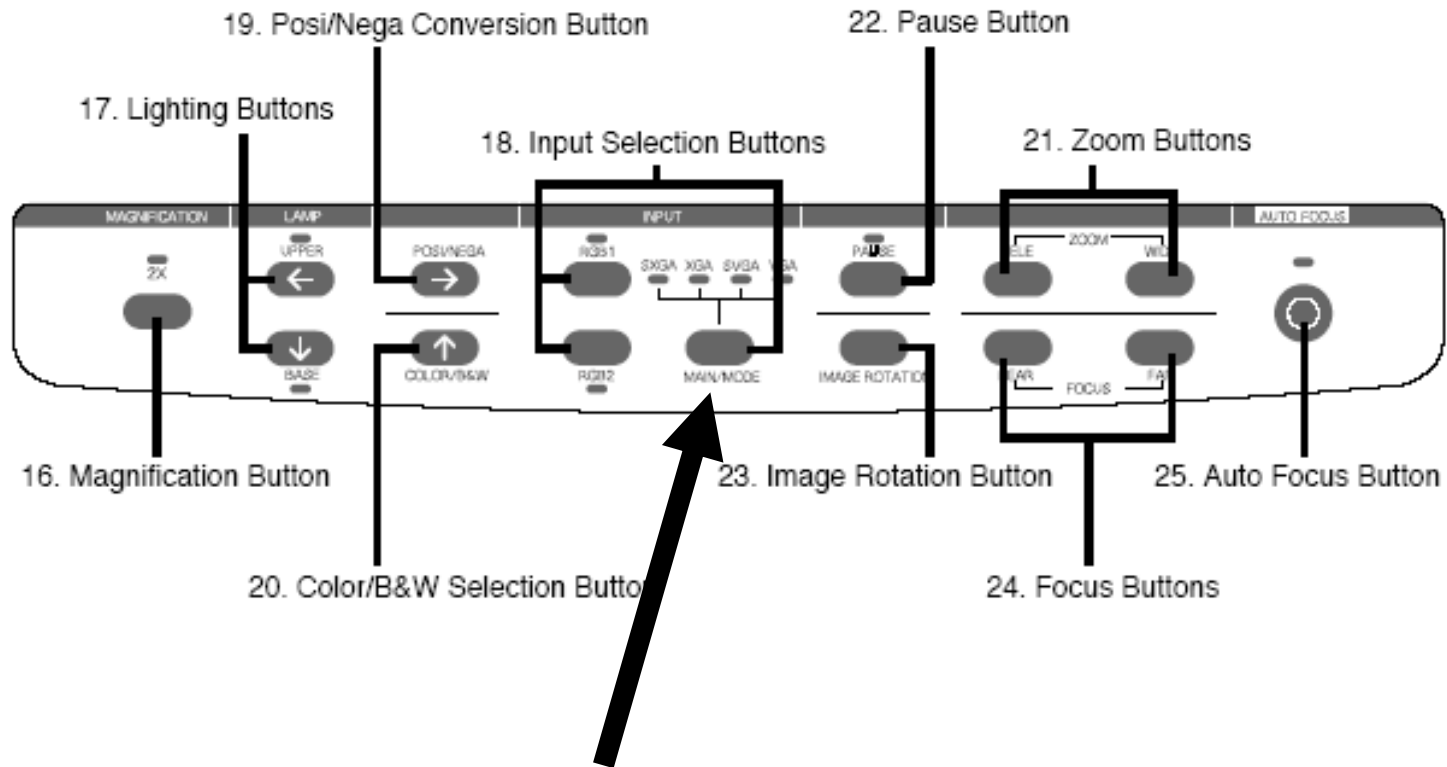

FOCUS and ZOOM

Play with the Focus and Zoom buttons to size the picture on the screen.
TELE to zoom in, WIDE to zoom out
NEAR to move focus near, FAR to move focus far

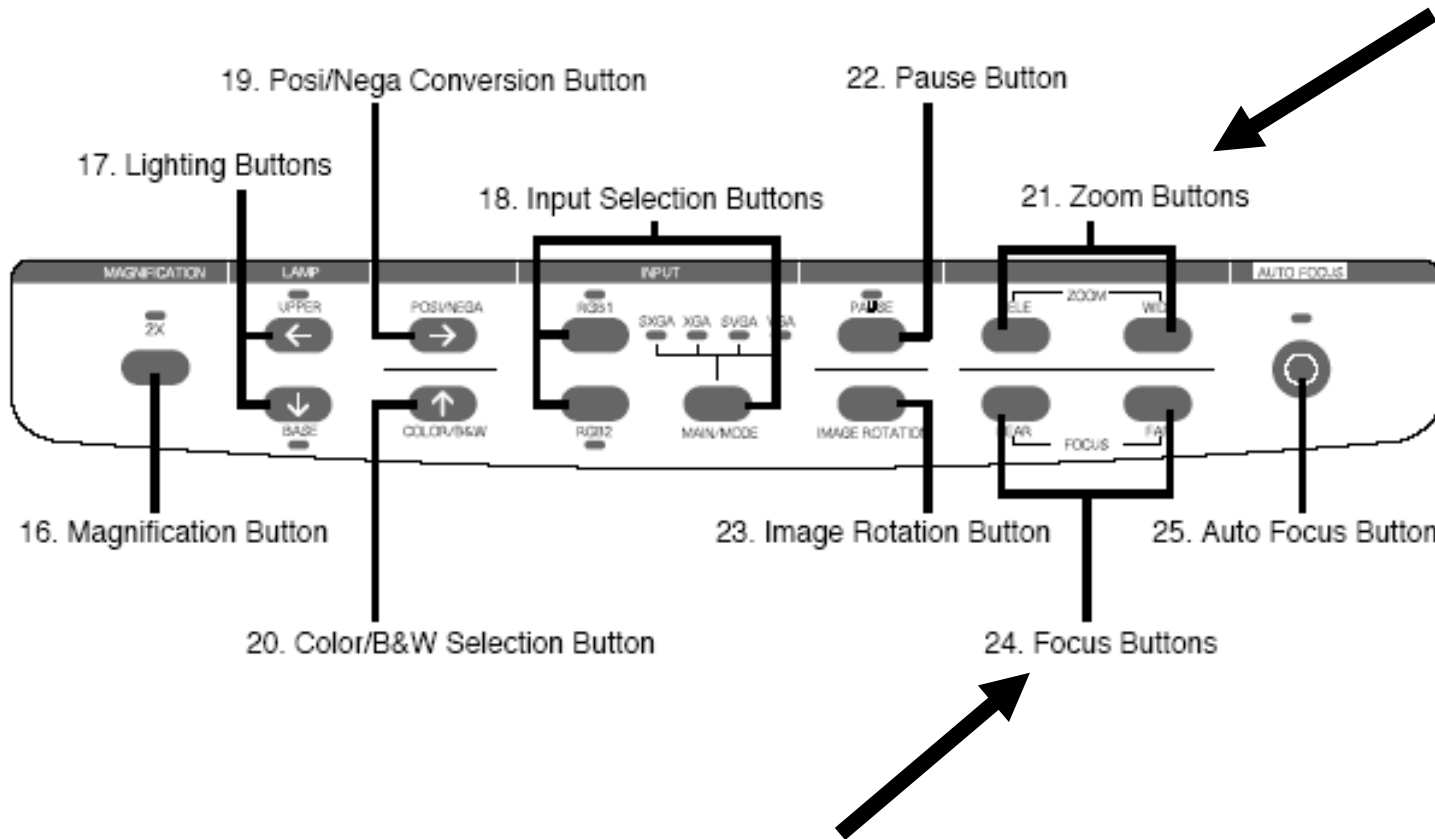

OTHER BUTTONS

PAUSE	To temporarily hold the image.
IMAGE ROTATION	To rotate the image. Each time this button is pressed, the image rotates counterclockwise by 90°.
POSI / NEGA	To select posi/nega modes.
COLOR / B&W	To select Color/B&W (Black&White) modes.
AF	To focus automatically.

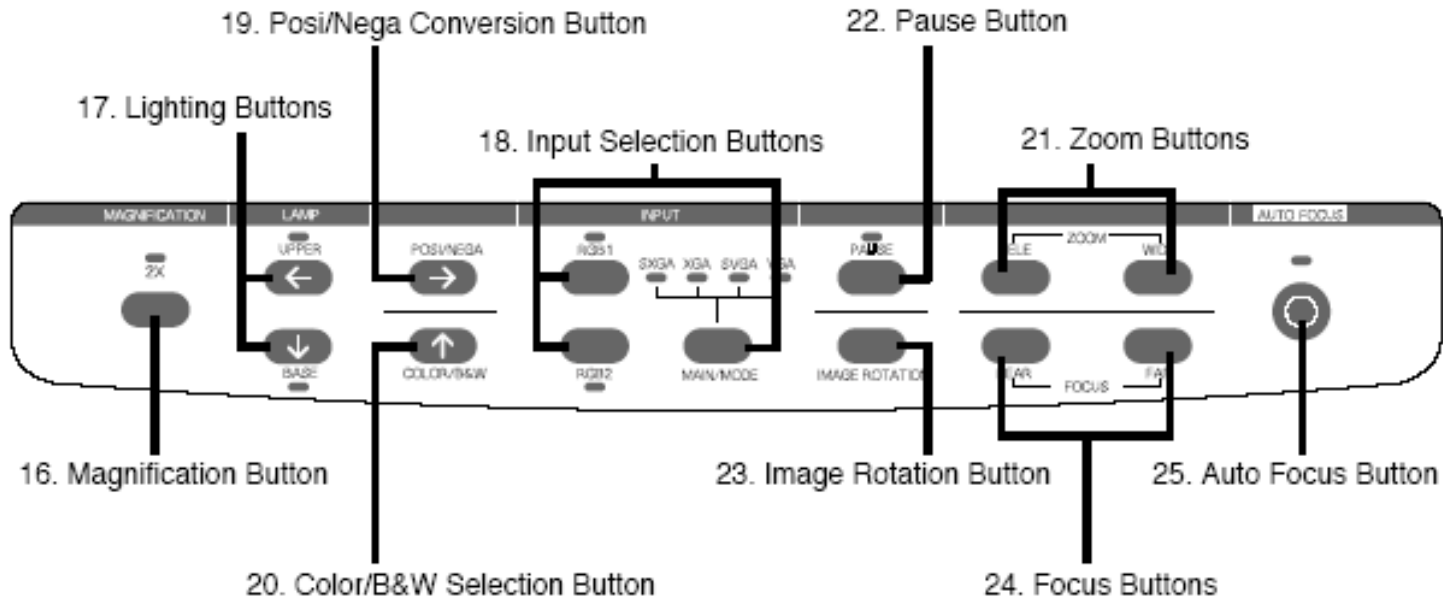

TURN OFF DOC CAMERA

Turn OFF the power switch

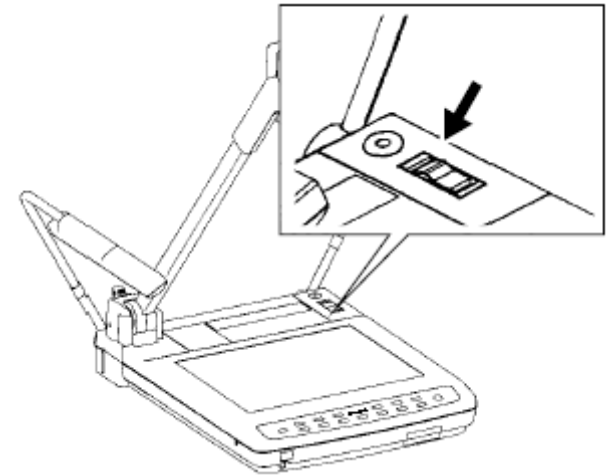

Press the column lock release and fold the Main column. The illustration shows the storage Position of the column. Never apply excessive force To the column.

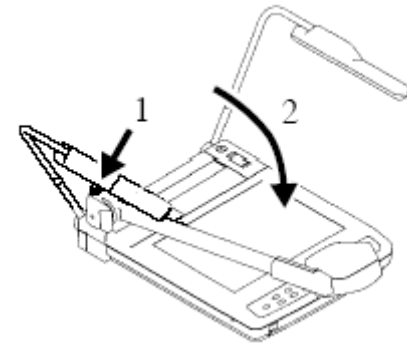

Fold down the lighting unit arms 3 and 4. Be sure to fold down arm 3 first as per the illustration.

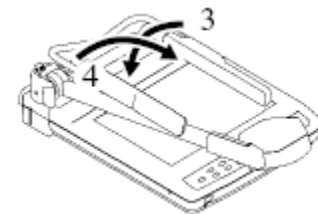

TURN OFF PROJECTOR

1. On the Projector Control, press the On/Off button.
The button blinks and a confirmation message is displayed.
2. Wait for the On/Off button to stop blinking and THEN before the message disappears, press the On/Off button again to turn off the projector.
3. On the Screen Control, press the UP switch.